

승 인	
정식승인	( )
한도승인	( )

# SPECIFICATIONS

CUSTOMER	
ITEM	LINE FILTER
MODEL NAME	NSH-3031
PART No	LF-UU1014-30mH(H-TYPE)
DATE	2015-06-11

검 토	심 사	승 인
승인유효기간	승인일로부터	년

신청회사명	<b>남선전자주식회사</b>	TEL	02-2689-9418
		FAX	02-2689-8628
주 소	Na-3506, Chungang Circulation Complex, 1258 Kurobon-dong, Kuro-Ku, Seoul, Korea, 152-721		

# 개 정 이 력

CUSTOMER				MODEL NO	NSH-3031
PART NO		LF-UU1014-30mH(H-TYPE)		ITEM	LINE FILTER
NO	DATA	Page	개 정 항 목	개 정 사 유	확인
1	2013-03-28			초도발행	
2	2015-06-11			WIRE 선경변경( $\phi 0.17$ 에서 $\phi 0.18$ 로 변경)	
3					
4					
5					
6					
7					
8					
9					
10					
11					
12					
13					
14					

**NAMSUN ELECTRONICS CO., LTD.**

Na-3506, Chungang Circulation Complex, 1258  
 Kurobon-dong, Kuro-Ku, Seoul, Korea, 152-721  
 TEL: 02-2689-9418 , FAX: 02-2689-8628

DESIGN

개발실  
추유섭  
2015-06-11

FILE NO.

CHECK

개발실  
이상순  
2015-06-11

APPROVAL

개발실  
조한석  
2015-06-11

NS-1014-30mH-NS-F6111

# APPROVAL SHEET

DATE	2015-06-11
PAGE	1 / 9

CUSTOMER			
PART NAME	LINE FILTER	MODEL NO.	NSH-3031
PART NO.	LF-UU1014-30mH(H-TYPE)	SIZE NO.	UU 1014

1. DIMENSION (UNIT:mm)

MARKING : NSH-3031

< TOP VIEW >

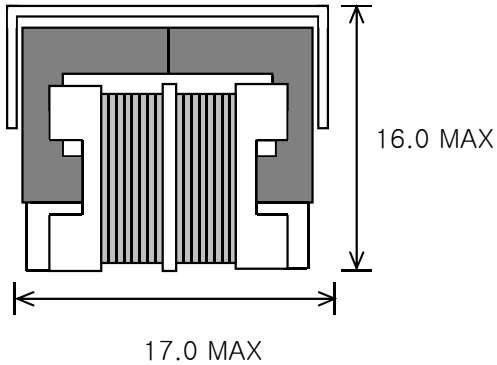

< FRONT VIEW >

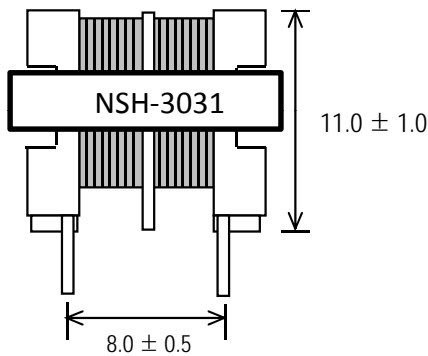

< BOTTOM VIEW >

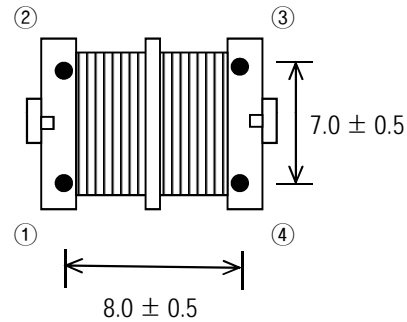

< BOTTOM VIEW >

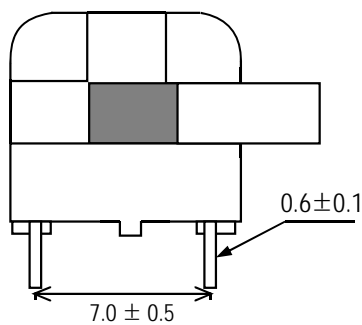

**NAMSUN ELECTRONICS CO., LTD.**

Na-3506, Chungang Circulation Complex, 1258  
Kurobon-dong, Kuro-Ku, Seoul, Korea, 152-721  
TEL:02-2689-9418 , FAX:02-2689-8628

DESIGN

CHECK

APPROVAL

개발실  
추유섭  
2015-06-11

개발실  
이상순  
2015-06-11

개발실  
조한석  
2015-06-11

FILE NO.

NS-1014-30mH-NS-F6111

# APPROVAL SHEET

DATE

2015-06-11

PAGE

2 / 9

CUSTOMER

PART NAME

LINE FILTER

MODEL NO.

NSH-3031

PART NO.

LF-UU1014-30mH(H-TYPE)

SIZE NO.

UU 1014

## 2. SCHEMATIC DIAGRAM

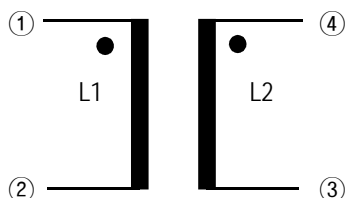

WINDNG

BOTTOM VIEW

C.C.W

N.C PIN

REMOVE PIN

## 3. WINDING SPECIFICATION

WINDING ORDER	COIL	TERMINAL (S - F)	WIRE	TURNS (Ts)	WINDING METHOD
1	L1	1 - 2	2 UEW $\phi$ 0.18 ( AWG # )	0.160Ts	SOLENOID WINDING
2	L2	4 - 3			SOLENOID WINDING

## 4. ELECTRICAL CHARACTERISTICS

NO	CLOSURE	TERMINAL NO.	SPECIFICATION	CONDITION
1	INDUCTANCE	1 - 2, 4 - 3	30mH MIN	HP-4284A at 1KHz, 1Vrms
2	DC RESISTANCE	1 - 2	$\Omega$ MAX $\Omega$ MAX	WHEATSTONE BRIDGE TAPE 2755, TYPE 3220
3	LAYER SHORT		AC 1.4KV, 1 MIN.	
4	DIELECTRIC STRENGTH	L1 - L2 COIL - CORE	AC1.5KV, 10mA . 1 MIN.	KIKUSUI : TOS-5050 (CURRENT SENSITIVE:5mA)
5	INSULATION RESISTANCE		100 Mohm MIN at DC 500V	MEGOHM METER (SM-5E)

**NAMSUN ELECTRONICS CO., LTD.**

Na-3506, Chungang Circulation Complex, 1258  
Kurobon-dong, Kuro-Ku, Seoul, Korea, 152-721  
TEL:02-2689-9418 , FAX:02-2689-8628

DESIGN

CHECK

APPROVAL



FILE NO.

NS-1014-30mH-NS-F6111

# APPROVAL SHEET

DATE 2015-06-11  
PAGE 3 / 9

CUSTOMER			
PART NAME	LINE FILTER	MODEL NO.	NSH-3031
PART NO.	LF-UU1014-30mH(H-TYPE)	SIZE NO.	UU 1014

## 5. ELECTRICAL CHARACTERISTICS

NO	ITEM	TEMINAL	SPECIFICATION	REMARKS
5-1	INDUCTANCE	L1 ( 1 - 2 )	30mH MIN	LEADER 745 LCR - METER at 1.0 KHz. 1.0V  ( 25 ℃ )
		L2 ( 4 - 3 )		
5-2	DIFFERENCE INDUCTANCE	L1 - L2	0.2 mH MAX	
5-3	DC RESISTANCE	L1 ( 1 - 2 )	ohm MAX	WHEATSTONE BRIDGE  (Y.E.W 2755)
		L2 ( 4 - 3 )		
5-4	DIELECTRIC STRENGTH	L1 COIL - L2 COIL	AC <u>2.0</u> KV r.m.s (1 MINUTE)	CUT OFF CURRENT : 5 mA  TOS - 8850
		L1 COIL - L2 COIL	AC <u>2.0</u> KV r.m.s (1 MINUTE)	
5-5	INSULATION RESISTANCE	COIL - COIL	100 M ohm MIN at DC 500V	TOS - 8850

**NAMSUN ELECTRONICS CO., LTD.**

76-29, GOCHEOK-DONG, GURO-GU, SEOUL, KOREA  
TEL : (02) 2687-8088 FAX : (02) 2687-5821

DESIGN

개발실  
추유섭  
2015-06-11

CHECK

개발실  
이상순  
2015-06-11

APPROVAL

개발실  
조한석  
2015-06-11

FILE NO.

NS-1014-30mH-NS-F6111

# APPROVAL SHEET

DATE 2015-06-11  
PAGE 4 / 9

CUSTOMER			
PART NAME	LINE FILTER	MODEL NO.	NSH-3031
PART NO.	LF-UU1014-30mH(H-TYPE)	SIZE NO.	UU 1014

## 6. SECTION DIAGRAM

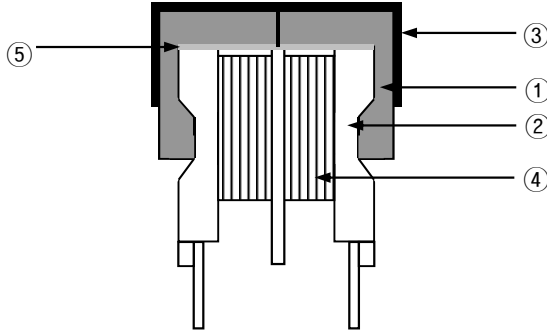

## 7. MATERIAL LIST

NO	COMPONENT	NAME OF MATERIAL	MANUFACTURER OF MATERIAL	REMARKS
1	CORE	GP-5/9 (UU 1014) HM-3 (UU 1014) R10K (UU 1014)	SAMWHA ELECTRONICS CO.,LTD. ISU CO.,LTD. DMEGC MAGNETICS CO.,LTD	
2	BASE	PHENOL RESIN (PF2736) 94V-0	BAKELITE GESELLSCHAFT MBH	E61040(M)
3	SPRING HOLDER	STAINLESS STEEL SUS 31	JIN BO INDUSTRIAL CO.	
4	WIRE	POLYURETHANE UEW 0.18Φ	TAIHAN ELECTRIC WIRE CO., LTD. DONGSUH ELECTRONICS CO.,LTD.	E109312(N) E210918
5	INSULATION TAPE	POLYESTER TAPE 0.025t x 4.5mm (Y)	HYUNDAI CHEMICAL CO.,LTD. DUCKSUNG TAPE CO.,LTD.	E162848(S) E105147(S)
6	VARNISH	DVA-1411	DAIHAN PAINT & INK CO.,LTD.	E93947(S)
7	SOLDER	SN98%,CU2%	ALPHA SOLDER CO.	

**NAMSUN ELECTRONICS CO., LTD.**

Na-3506, Chungang Circulation Complex, 1258  
Kurobon-dong, Kuro-Ku, Seoul, Korea, 152-721  
TEL:02-2689-9418 , FAX:02-2689-8628

DESIGN	CHECK	APPROVAL
개발실 추유섭 2015-06-11	개발실 이상순 2015-06-11	개발실 조한석 2015-06-11
FILE NO.	NS-1014-30mH-NS-F6111	

<h1 style="margin: 0;">APPROVAL SHEET</h1>	DATE	2015-06-11
	PAGE	5 / 9

CUSTOMER			
PART NAME	LINE FILTER	MODEL NO.	NSH-3031
PART NO.	LF-UU1014-30mH(H-TYPE)	SIZE NO.	UU 1014

<b>TAIHAN ELECTRIC WIRE CO., LTD.</b> 194-15 1-KA HOEHYUN-DONG CHUNG-KU CPO BOX 2624, SEOUL KOREA	<b>E 109312 (N)</b>
---	---------------------

Mtl	Coat type	ANSI	
Dsg	BC	Overcoat	Type
Magnet wire.			T1
EI-AIW	Ester-imide	Polyamide-imide	MW35.73 200
AL EI-AIW	Ester-imide	Polyamide-imide	MW35 240
EIW	Ester-imide	-	MW30.72 180
EIW-N	Ester-imide	Polyamide	MW76 180
AIW	Polyamide-imide	-	- 220
PEW-N	Polyester	Polyamide	MW76 180
SEIW	Solderable	-	MW77 180
	Polyester-imide		
UEW	Polyurethane	-	MW75 130
UEW-N	Polyurethane	Polyamide	MW80 155

Reports : April 2, 1987; April 2, 1987; April 2, 1987; April 2, 1987; April 2, 1987; April 2, 1987; April 2, 1987; April 2, 1987; April 2, 1987; April 2, 1987.

<b>DONG SUH ELECTRONICS CO., LTD</b> 55-1 BUNSU 3-RI KWANGTAN-MYUN PAJU KYONGGI-DO 413-850, KOREA	<b>E 210918</b>
---	-----------------

Mtl	Mark	Coat type	ANSI	
Dsg	Dsg	BC	Overcoat	Typ(+)
DSUEW-100	(1)	Polyurethane	-	MW75C 130
UEW	(1)	polyurethane	None	MW79 155
				MW75 130(2)
PEW	(1)	Polyester	None	MW30 180
				MW5 155(2)

- (1) Marked designations are the same as the material designations.
- (2) Additional consideration is needed before its use in System's thermal aging.

Marking : Company name, materal designation or marked designation on package or reel, and Recognized Component Mark.

<p style="color: blue; font-weight: bold; font-size: 1.2em; margin: 0;"><u>NAMSUN ELECTRONICS CO., LTD.</u></p> <p style="margin: 0;">Na-3506, Chungang Circulation Complex, 1258          Kurobon-dong, Kuro-Ku, Seoul, Korea, 152-721          TEL:02-2689-9418 , FAX:02-2689-8628</p>	DESIGN	CHECK	APPROVAL
			
	FILE NO.	NS-1014-30mH-NS-F6111	

<h1 style="margin: 0;">APPROVAL SHEET</h1>	DATE	2015-06-11
	PAGE	7 / 9

CUSTOMER			
PART NAME	LINE FILTER	MODEL NO.	NSH-3031
PART NO.	LF-UU1014-30mH(H-TYPE)	SIZE NO.	UU 1014

BAKELITE AG E 61040 (M)  
 POSTFACH 7154 58609, ISERLOHN-LETMATH FED  
 REP GERMANY

Phenolic molding compound(PF), desingnated "Rutaform" or "furnished in the form of pellets or powder

PF2836@	BK	1.50	94V-0	150	150	150	0	2	~	5	~
PF2736@	NC,GN	0.81	94V-0	150	150	150	0	2	~	5	~
	BK										
	ALL	0.81	94V-1	150	150	150	0	2	~	5	~
	ALL	1.50	94V-0	150	150	150	0	2	0	~	~
		3.00	94V-0	150	150	150	0	2	0	5	
PF2560@	ALL	1.50	94V-1	150	150	150	~	~	~	~	~
	BK,NC	1.50	94V-0	150	150	150	~	~	~	~	~
	ALL	3.00	94V-0	150	150	150	~	~	~	~	~
PF31@	ALL	1.50	94V-1	150	150	150	1	1	~	6	~
		3.00	94V-0	150	150	150	0	1	~	~	~
PF2744@	ALL	1.50	94V-0	150	150	150	0	1	~	5	~
PF2855@	ALL	3.00	94V-0	150	150	150	0	3	~	5	~
PF6506@	ALL	1.50	94V-0	150	150	150	0	2	~	5	~

<p style="color: blue; font-weight: bold; margin: 0;"><u>NAMSUN ELECTRONICS CO., LTD.</u></p> <p style="margin: 5px 0;">Na-3506, Chungang Circulation Complex, 1258          Kurobon-dong, Kuro-Ku, Seoul, Korea, 152-721          TEL:02-2689-9418 , FAX:02-2689-8628</p>	DESIGN	CHECK	APPROVAL
			
	FILE NO.	NS-1014-30mH-NS-F6111	



<h1>APPROVAL SHEET</h1>	DATE	2015-06-11
	PAGE	8 / 9

CUSTOMER			
PART NAME	LINE FILTER	MODEL NO.	NSH-3031
PART NO.	LF-UU1014-30mH(H-TYPE)	SIZE NO.	UU 1014

HYUN DAI CHEMICAL CO., LTD  
 258 YEULMI-RI SILCHON-MYON KWANGJU  
 KYONGGI-DO 464-870 KOREA

E 162848 (S)

Polyester tape with apriile adhedive, cat. no. 800 for use at temperature not mxddading 190 c.  
 Marking company name. catalog daeignation and temperature rating ptinted on darion .wrapper  
 or core.

See General informtion precading three recognitiona

For use only equipment where the adceptabination la datermined by undarwrii.  
 ars Laboratorles inc.

Report October 20. 1994.

1.06E+08      underwriters Laboratoles inc.      Dil/0264017

and Recognized Component Mark.

DUCK SUNG TAPE CO LTD  
 DAESUNG BLDG 677 JAYANG-DONG SUNGDONG-KU,  
 SEOUL 133-190 KOREA

E 105147 (S)

Polyester film insulating tape,cat.no. DTS-204 rated 130 C.

Acetate cloth insulating tape,cat.no. 231 rated 105 C.



Glass cloth insulating tape,cat.no. 220-B rated 130 C.

Acetate cloth insulating tape,cat.no. DTS-230 rated 105 C.

Marking:Company name or trademark    or "E105147" and catalog designation  
 printed on carton, wrapper or core.

**NAMSUN ELECTRONICS CO., LTD.**

Na-3506, Chungang Circulation Complex, 1258  
 Kurobon-dong, Kuro-Ku, Seoul, Korea, 152-721  
 TEL:02-2689-9418 , FAX:02-2689-8628

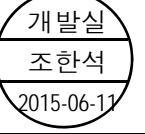
DESIGN	CHECK	APPROVAL
		
FILE NO.	NS-1014-30mH-NS-F6111	

# APPROVAL SHEET

DATE 2015-06-11  
PAGE 8 / 9

CUSTOMER			
PART NAME	LINE FILTER	MODEL NO.	NSH-3031
PART NO.	LF-UU1014-30mH(H-TYPE)	SIZE NO.	UU 1014

- VARNISH -

OBOR2 October 8, 1990  
Component - Varnishes

DAIHAN PAINT & INK CO LTD.				E 93947 ( S )	
( B-cont. from a card )					
DVA-1411	Helical Coil	Polyester	Polyamide	MW24	180
	Twisted Pair	Polyester	Polyamide	MW24	155
DVA-1422	Helical Coil	Polyester	Polyamide	MW24	155
	Twisted Pair	Polyester	Polyamide	MW24	155
DVB-2148L	Twisted Pair	Polyester		MW5	155
	Helical Coil	Polyester		MW5	155
	Twisted Pair	Polyester	Polyamide	MW24	155
	Helical Coil	Polyester	Polyamide	MW24	155

Marking : Company name and varnish designation on shipping container  
Report L : September 10, 1986.

**NAMSUN ELECTRONICS CO., LTD.**

Na-3506, Chungang Circulation Complex, 1258  
Kurobon-dong, Kuro-Ku, Seoul, Korea, 152-721  
TEL:02-2689-9418 , FAX:02-2689-8628

DESIGN	CHECK	APPROVAL
개발실 추유섭 2015-06-11	개발실 이상순 2015-06-11	개발실 조한석 2015-06-11
FILE NO.	NS-1014-30mH-NS-F6111	

# APPROVAL SHEET



DATE 2015-06-11  
PAGE 9 / 9

CUSTOMER			
PART NAME	LINE FILTER	MODEL NO.	NSH-3031
PART NO.	LF-UU1014-30mH(H-TYPE)	SIZE NO.	UU 1014

ITEM NO	WIRE (130℃)	P.S TAPE (130℃)		
1	OK	OK		
2	"	"		
3	"	"		
4	"	"		
5	"	"		
6	"	"		
7	"	"		
8	"	"		
9	"	"		
10	"	"		

**NAMSUN ELECTRONICS CO., LTD.**

Na-3506, Chungang Circulation Complex, 1258  
Kurobon-dong, Kuro-Ku, Seoul, Korea, 152-721  
TEL: 02-2689-9418 , FAX: 02-2689-8628

DESIGN	CHECK	APPROVAL
		
FILE NO.	NS-1014-30mH-NS-F6111	